



Combo prep station

Shallow above standard drawer (SVS2)
or standard above shallow drawer (VSS2)



Blast Chill

For added functionality a BC option is available with Standard Drawers

Applications

- Ergonomic storage solution, right at the point of use
- Ideal for meat, deli & dessert prep
- Perfect for garnish and 'mise en place' generally
- Frozen storage by the deep fry station, with worktop mounted Fry Basket Rack as an optional extra

Storage Capacity

Standard Drawer	Shallow Drawer
Gastronorm Pans 4 x 1/1 GN 100 mm Deep or equivalent	Gastronorm Pans 4 x 1/1 GN 75 mm Deep or equivalent
Maximum Weight 40 kg of Food	Maximum Weight 30 kg of Food
Volume 86 Litres	Volume 65 Litres

Hydrocarbon R600a Refrigerant

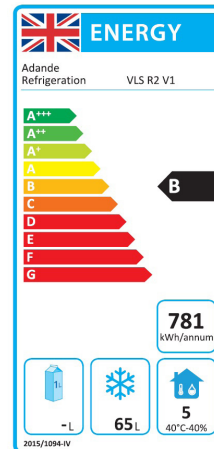

Shallow Drawer

'B' Energy Rating in freezer mode
'A' Energy Rating in fridge mode
(Consumption 325 kWh/annum)

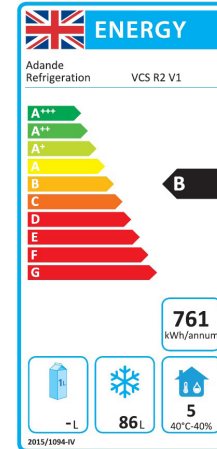

Standard Drawer

'B' Energy Rating in freezer mode
'A' Energy Rating in fridge mode
(Consumption 307 kWh/annum)



Climate Testing

Tested to **Climate Class 4** (30°C & 55% relative humidity) for temperature and energy consumption and to **Climate Class 5** (40°C & 40% relative humidity) for temperature

Electrical

Mains Supply
230 Vac 50 Hz

Power Socket (included)
Correct 2 or 3 Pin Plug fitted for each country

Mains Lead (included)
2 Metre Coiled Lead



Options

Standard above shallow drawer – code: [SVS2](#) or shallow above standard drawer – code: [VSS2](#)

PREP STATION + SOLID WORKTOP (W)	High castor base (HC)		Standard castor base (C)		Small castor base (SC)		Rollers & feet base (R)		Small rollers & feet base (SR)		Locking roller base (L)		Small locking roller base (SL)		
	Finished height	913 mm	VSS2/HCW SVS2/HCW	842 mm	VSS2/CW SVS2/CW	821 mm	VSS2/SCW SVS2/SCW	797 mm	VSS2/RW SVS2/RW	787 mm	VSS2/SRW SVS2/SRW	797 mm	VSS2/LW SVS2/LW	787 mm	VSS2/SLW SVS2/SLW
Load-bearing capacity	137 kg		214 kg		439 kg		240 kg		241 kg		213 kg		213 kg		

For full options please see our [Drawer Customising](#) and [Accessories](#) pages

Plan View

Combo prep station ([VSS2 & SVS2](#))
With open drawer

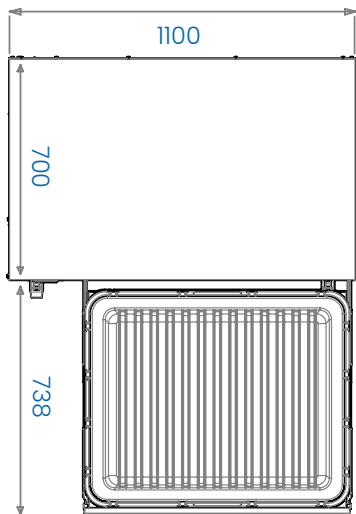

Elevation

Combo counter prep station ([VSS2 & SVS2](#))
Standards castors (C)
Solid worktop (W)
[VSS2/CW](#) (illustrated) & [SVS2/CW](#)

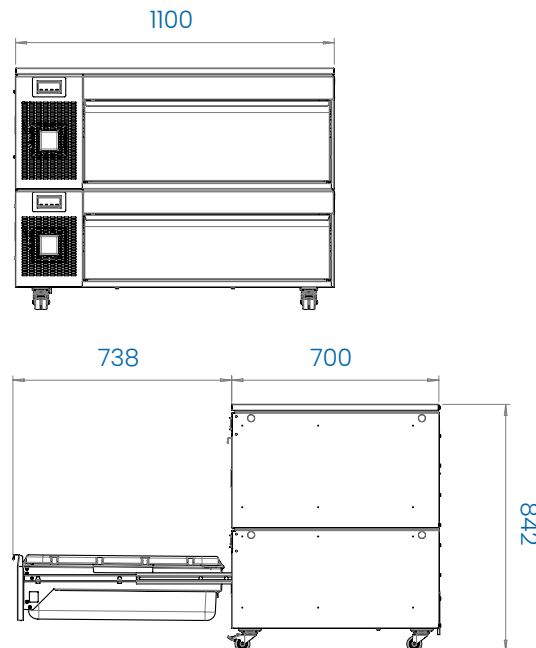

Tops



Double Drawer Module



Base

